

Hydraulic Wedgie and Spread Cylinders

▼ Shown from top to bottom: WR-15, A-92, WR-5



- WR-5: For use in very confined work areas
- WR-15: For long stroke spreading applications
- Single-acting, spring return
- A-92: Spreader attachment; threads on RC-Series 10 ton cylinders (except RC-101).

A WR Series



Capacity:
0,75 - 1 ton

Tip Clearance:
12,8 - 35 mm

Maximum Spread:
292 mm

Maximum Operating Pressure:
700 bar



RC-Series Cylinders

10 ton RC-Series cylinders (except RC-101) fit into A-92 Spreader Attachment.

Page: 8



Best Match Hand Pump

To power your Wedgie and Spreader Attachment the P-392 hand pump is an ideal choice.

Page: 68

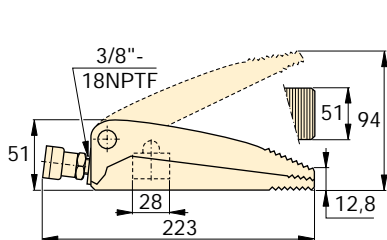

WR-5

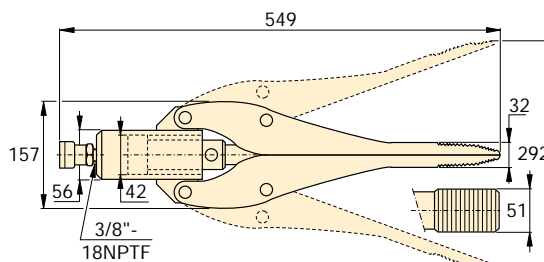

WR-15

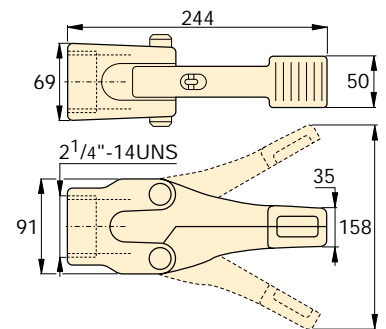

Cylinder Capacity	Tip Clearance	Model Number	Maximum Spread	Cylinder Effective Area	Oil Capacity	
ton (kN)	mm		(mm)	(cm ²)	(cm ³)	(kg)
1 (8,9)	12,8	WR-5	94	6,5	10,0	2,3
0,75 (6)	32	WR-15	292	14,5	64,1	11,3
1 (8,9)	35	A-92	158	-	-	3,6

A WR-5 wedgie cylinder is used to position a concrete block on a construction site. ▶

